



Sangamesh B. Herakal
Asst. Professor,
Dept. of Mechanical Engg.
Holy Mary Institute of Technology & Science
Hyderabad-501301
Email: sachin.herakal@gmail.com

including with surface risen or entrenched sensors and actuators having ability to take corrective
Dr.S.Chakradhara Goud
Professor and Principal
Dept. of Mechanical Engineering
Sri Sarada Institute of Science and Technology
Hyderabad-508116
Email: cgsakki@yahoo.com

Abstract

This abstract studied the application of piezoelectric actuators for fixed form controlling of combination plate. Electro-mechanically coupled mathematical model is used for the analysis. The main part of this piece of writing focuses on the fixed shape control. It has been defined here as the shape controlling parameters, as well as actuation voltage and actuator orientation configuration, such that the structure that is activated. Exploitation of these parameters will decide as secure as probable to the preferred shape. A fixed aspect of design for shape control analysis of piezoelectric plastic-coated combination plate by using Ansys is described in this thesis. In the plastic-coated compound plate piezoelectric actuators and sensors are designed as supplementary layers either externally or entrenched. A definite component of software Ansys can be exploited to model and was successfully validated with experimental and numerical results that are readily available in the literatures. The present examination illustrates that the appliance of proper voltage to piezoelectric actuator, preferred form of the combined plate can be obtained.

Keywords- Composite plate, sensor, smart structure, FEM.

I. INTRODUCTION

The requirements for the composition with the self supervising and self capacity particularly in aerospace appliance have resulted in an extraordinary growth in the exploring and progressing the smart structure. However smart design can be understood as a model composed with fresh flexible resources, called the substance

action Wang. et. al (1997).The direct consequence piezoelectric have the capability to produce energy in certain quantity to apply mechanical force,

and the piezoelectric effect is exactly the inverse of the direct result. Plastic-coated compound Plate is selected as substrate fir its high strength to weight and stiffness to weight ratios. The plastic-coated composite plate has become more apt to be employed in many appliances particularly in aerospace because of possessing these qualities.

A composite is a constructional substance comprising two or more united elements that are blended at a macroscopic level and are unable to be dissolved in each other. One element is called the strengthening phase and the one out of which entrenched is entitled the matrix. The revitalizing phase substance consists of particles, fibers, or flakes. The resources connected to matrix phase are usually constant. These compound systems and its examples incorporate strengthened concrete with steel and epoxy invigorated with graphite fibers and wood, where the lignin matrix is reinforced with cellulose fibers and bones in which the bone-salt plates made of calcium and phosphate ions reinforce soft collagen etc.

II. SMART STRUCTURE

The basic requirements of an intelligent structure are the following three capabilities: sensing, processing/controlling/ actuating. This intelligent structure receives and increases attention in various fields such as biomedical, aerospace structure, civil, military, locomotive, flight control. Another application is shape control where the figure of structure is modified to decide

to a preferred form by actuating the appropriate actuators.

A. Selected Applications

The need to modify the structure's shape, while in operation, increases the opportunity for implementation of shape control. By integrating adaptive materials into structures, the complete structure of the form can be manipulated as to finalize certain desired shapes. These appliances may vary from manage the shape of aerodynamic surfaces such a metal for a huge flexible space structures or space aerial reflectors. It is believed that, these intellectual actuators incorporated within the form can generate little in-plane diversion which, in return may create a larger out-of-plane alterations. A set of actuators will be circulated all through the structure. The objectives of form controlling include deciding the degree of input indication to apply to each actuator, or the optimal layout of actuators, besides determining any other variables that might affect the behavior of the structure, just because of getting a form which is as near as probable to the preferred shape. A lot of research and studies resulted in variety of forms gained by altering the parameters of input like, the size of actuator, site& its position and voltage of actuator. Hence it can also describe the practicality and possible appliance of form controlling of structures.

B. Piezoelectric Effect

A piezoelectric material is one which generates an electrical charge when a mechanical pressure is practically implemented (the substrate is pressed or extended). Conversely, a mechanical diversion (the substrate contracts or enlarges) is provided in case of application of an electric field. This effect is shaped in crystals which has no particular balance. To elucidate it we need to look at the personal particles which build up crystals. Every particle has been divided with one ending charged negatively and the ending charged positively, therefore, is named as *dipole*. However, atoms can be caused for not only building up of the particles but also in forming the molecules. The polar alignment is a fanciful line which goes throughout the middle of two charges on the particle. The polar alignment of all dipoles stays in a single track in a Monocrystal. However, the crystal is described to be a balanced one, reason is, if you happen to slash the crystal at any angle, the two pieces

connected to the ensuing polar alignments will stay in the similar way as the original.

To implement a dynamic electrical field practically, the polycrystal is to be heated up just to generate the piezoelectric consequences. The heat let the particles to shift more liberally and all of the dipoles in the crystal to line up will be compelled by the electricity and be faced almost in the same path as displayed in **figure 1**.

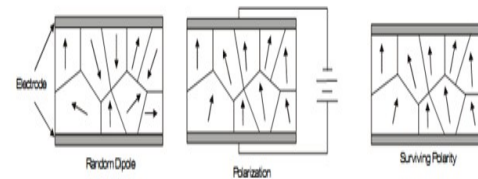

Fig1: division of earthenware material to produce piezoelectric results which is now examined in the crystal. The consequences of piezoelectric are described in **Figure 1.1** which indicates (a) the piezoelectric resources without any pressure or charging. The energy of the same division connected to the poling power can be showed between the electrodes if the material happens to be compacted. (b).The power at the reverse polarity will be showed clearly only if is expanded (c). The material will be distorted if energy is deformed. Sometimes power with the same division will result in material expansion (e). The material will also be shaken at the same regularity as the signal if an AC signal is used then.

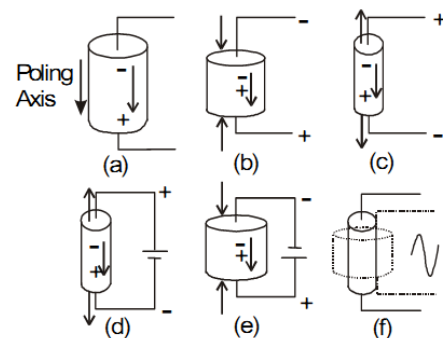

Fig 1.1: Piezoelectric effect

III. MATHEMATICAL MODELING

This equation of piezoelectric field and maintaining the definite part of for creation of the intellectual structure.

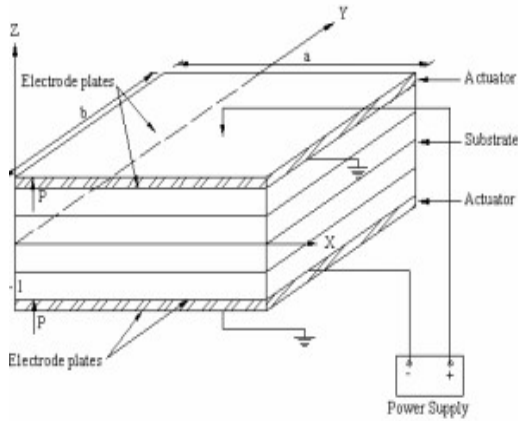

Fig2: Piezoelectric effect

The work considered to be earliest one, using the (FE) Finite Element technique for structural modeling that included piezoelectric effects was done by Allik & Hughes (1970). Since the beginning of research in the field of active/intelligent structures, several authors, most notably Tzou & Tseng (1988, 1990); Tzou et. al. (1990); had applied the FE technique which is advantageous for cases when exact analysis is too complex.

A. General Formulation

The normal application is depended on the Hamilton Energy Variation Principle as given in equation

$$(1)$$

The first main difference between conventional and piezoelectric Finite Element formulation is the presence of an electrical contribution to the potential energy in the Lagrangian (L), and work (W) terms. This will lead to the use of constitutive equations that not only relate stress (s) and strain but also electric fields (E) and displacements (D). The next major difference is that in the piezoelectric FE technique, there is an additional variable or degree of freedom besides the displacements (u), that is the power potential (φ). All physical variables, such as σ, ε, E, D, are converted into the variables (u, φ). The Electric field and pressure will be obviously communicated in other words of u and φ respectively; D and S are connected to ε and E through the piezoelectric constitutive equations. Hence the reason that most FE formulations used the stress formulation instead of the strain Formulation of the piezoelectric constitutive equations. The displacements and electrical possibility will be converted into nodal

displacements and nodal potentials by using shape interpolation functions Equation 2

$$u = Nu \{u_i\}$$

$$\phi = N_\phi \phi_i \quad (2)$$

Replacement these words through the integral equations obtained from various principles, lead to the equation of linear matrix element which has the shape for the generalized equation of movement as exposed in Equation.3

$$\begin{bmatrix} [M_{uu}] & 0 \\ 0 & 0 \end{bmatrix} \begin{bmatrix} \{\ddot{u}_i\} \\ \{\ddot{\phi}_i\} \end{bmatrix} + \begin{bmatrix} [C_{uu}] & 0 \\ 0 & 0 \end{bmatrix} \begin{bmatrix} \{\dot{u}_i\} \\ \{\dot{\phi}_i\} \end{bmatrix} +$$

$$\begin{bmatrix} [K_{uu}] & [K_{u\phi}] \\ [K_{\phi u}] & [K_{\phi\phi}] \end{bmatrix} \begin{bmatrix} \{u_i\} \\ \{\phi_i\} \end{bmatrix} = \begin{bmatrix} \{F\} \\ \{Q\} \end{bmatrix}$$

$$(3)$$

Equation3 is for dynamic analysis for static analysis Mass (M) and damping coefficient (C) are taken to be zero.

B. The First-Order Shear Deformation Theory, FSdT

Reissner-Mindlin's theory is used for plates on the laminate translational displacements in relation to a specified coordinate system by use of the laminate cross section in the x-z plane.

We can write these displacement formulas on x and y direction as follows:

$$(4)$$

Which indicate that are the rotations of a transverse regarding the X and Y axes, respectively.

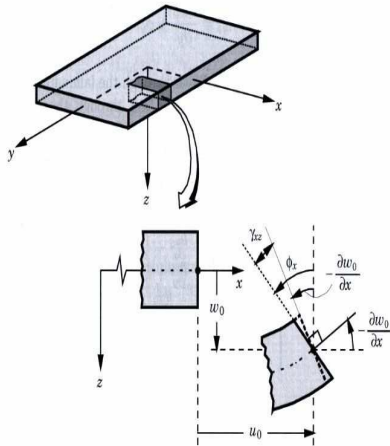

Fig3: Un-deformed and distorted geometries of rim of plate based on the assumptions of the first-order plate theory.

The strain components on the position plate are,

(5)

The curvatures of the laminate are,

(6)

It is convenient to split the strain vector into two parts, where the bending is part and is the shear part

(7)

(8)

IV. RESULTS AND DISCUSION

A. Validation of Model

The FE model developed in the earlier chapter is first validated and used in the further analysis. So as to confirm the correctness of present model a Bimorph Piezoelectric Beam indicated in **fig 4.1** is first studied by Z Wang et al.(1997).

This beam comprises two same PVDF Uniaxial Beam with opposite polarities. The cantilever beam is modeled by five identical plate elements. The

properties of material related to VDF are listed in Table 1.

The explanation of deflection of the beam based on theory given by Tzou H. S (1989)

(9)

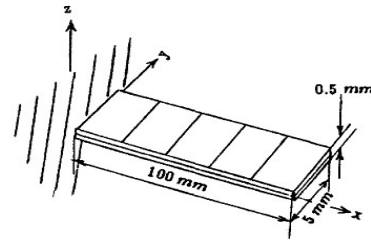

Fig 4: Piezoelectric PVDF BIMORPH BEAM.

Beam's deflection is calculated for different distances between 20mm to 100mm along the length of beam. The outcomes are displayed in **Tables 2** along with results of Tseng [1990]. The results show the close agreement between theoretical and the present finite element solutions.

Table 1: Material properties of the main structure and piezoelectric

Property	PVDF	Graphite/Epoxy
E ₁	0.2e10 N/m ²	0.98e11 N/m ²
E ₂	0.2e10 N/m ²	0.79e10 N/m ²
G ₁₂	0.775 e9 N/m ²	0.56e10 N/m ²
ν ₁₂	0.29	0.29
ν ₂₁	0.28	0.28
ρ	1800kg/m ³	1520 kg/m ³
e ₃₁	0.046c/m ²	0
e ₃₂	0.046c/m ²	0
e ₃₃	0	0
ε ₁₁	0.1062e-9F/m	0
ε ₂₂	0.1062e-9F/m	0
ε ₃₃	0.1062e-9F/m	0

Table 2: PVDF BIMORPH BEAM'S Deflection (for a unit voltage) (m)

Dist(M)	RPIM Theory	Tseng(1990)	Present FEM
0.02	0.0140e-6	0.0150e-6	0.0130e-6
0.04	0.0552e-6	0.0569e-6	0.0523e-6
0.06	0.1224e-6	0.1371e-6	0.124e-6
0.08	0.2208e-6	0.2351e-6	0.214e-6
0.1	0.3451e-6	0.3598e-6	0.336e-6

G_{23}	24.2e9	7.10e9
ρ	7600 kg/m ³	1600 kg/m ³
d_{31}	22.86	-
d_{32}	22.86	-
K_{11}	15.3e-9 F/m	-
K_{22}	15.3e-9	-
K_{33}	15e-9	-

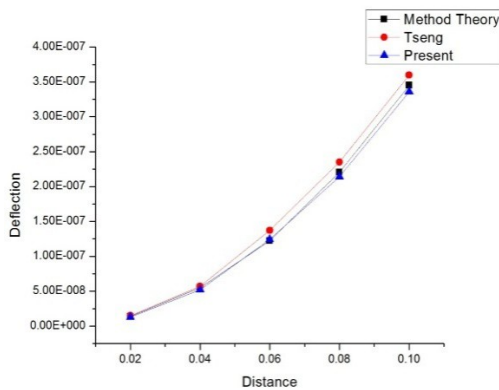

Fig 5: PVDF Bimorph Beam's Deflection (for a unit voltage) (m)

B. Cantilever Plate with UDL

A cantilevered plastic-coated compound plate is examined both the layers of higher and lower regularly connection by piezoelectric ceramics. The plate consists of four composite layers and two piezolayers. Plate is made of T300/976 graphite-epoxy composites and piezoceramic is PZT G 1195N.

Table 2: Material Property of PZT G1195N Piezoceramics and T300/976 Graphite-Epoxy Composites

Property	PZT	T300/976
E_{11}	63e9	150e9
E_{22}	63e9	9e9
E_{33}	63e9	9e9
ν_{12}	0.3	0.3
ν_{13}	0.3	0.3
ν_{23}	0.3	0.3
G_{12}	24.2e9	7.10e9
G_{13}	24.2e9	2.5e9

Consider composite plate [P/-45/45] as is originally flat and is then exposed to uniformly distributed load of 100 N/m². To flatten the plate an active voltage is added incrementally until center line deflection of plate is reduced to desired limits.

For the present analysis layer, the plate dimensions are (0.2m x 0.2m). The plate consists of four composite layers and two outer piezo layers. Total thickness of non-piezoelectric compound plate is 0.001m and piezo layer related to thickness is 0.0005m.

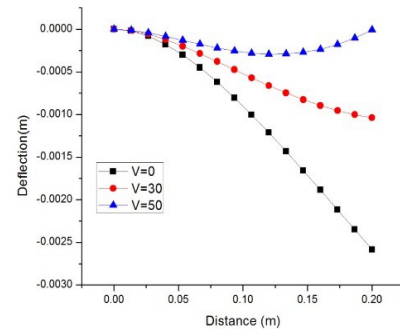

Fig 6: Cantilever lamination and its Centerline deflection [p/-45/45] as under uniform loading and input voltages of diverse actuators.

The above two examples Fig 5 and Fig 6 shows that the present FE model produces results, which are very much consonant with the available literatures.

C. Piezoelectric Layer and its Optimum Location

Case 1: Piezoelectric Layer at the each corner of Plate

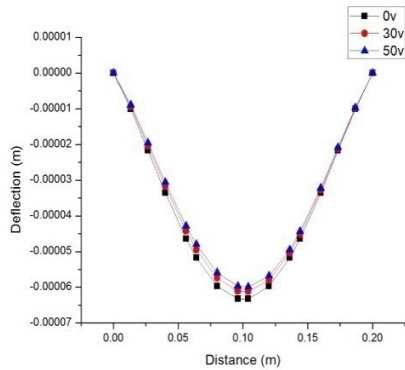
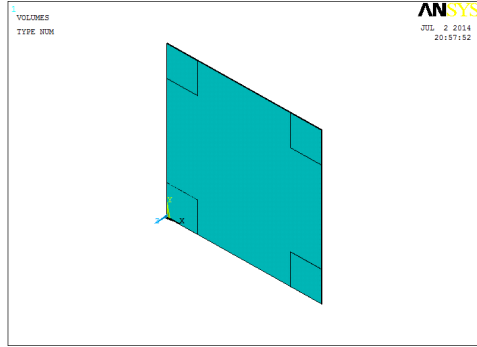

Fig 7: Centerline deflection of plate [p-45/45]_{as}
P=100N/m², V=0,30,50

Case-2 Piezoelectric Layer central to Each Edge

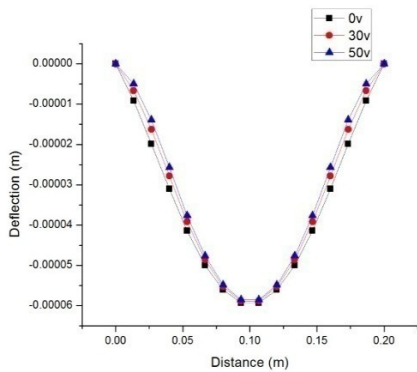
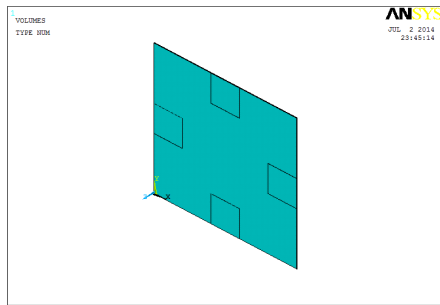

Fig 8: Centerline deflection of plate [p-45/45]_{as}
P=100N/m², V=0,30,50

Case-3 Piezoelectric Layer at the heart of Plate

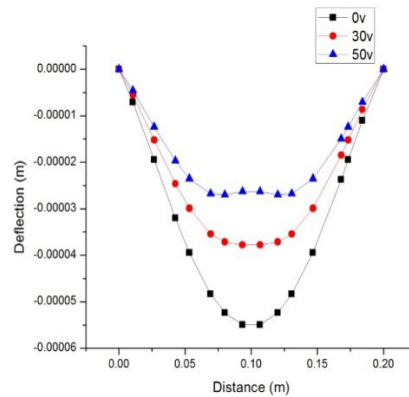
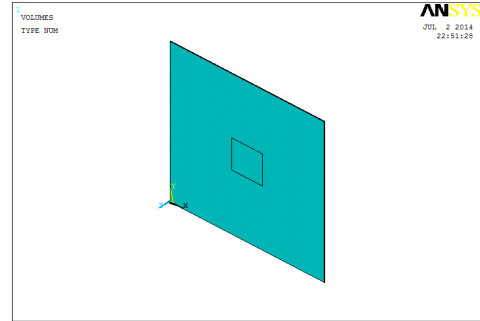
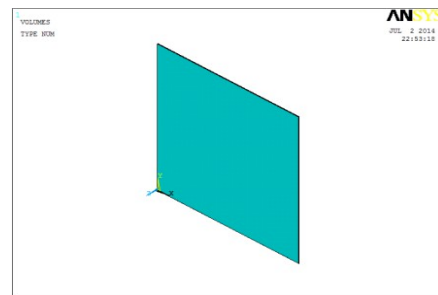

Fig 9: Centerline deflection of plate [p-45/45]_{as}
P=100N/m², V=0,30,50

Case-3 Piezoelectric Layer throughout the Plate



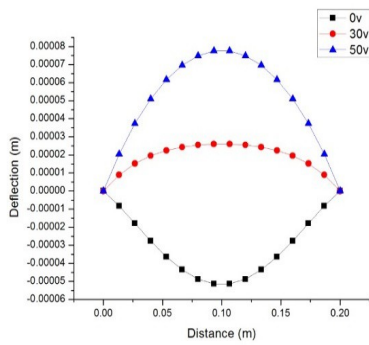

Fig 10: Centerline deflection of plate [p-45/45]_{as} P=100N/m², V=0,30,50

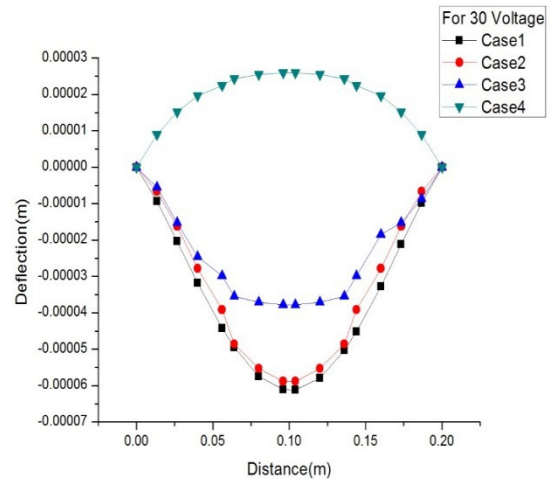

Fig 11: Centerline deflection for P=100N/m², V=30 for different cases

D. Comparisons of Centerline Deflection for Different Voltages for the Different Cases

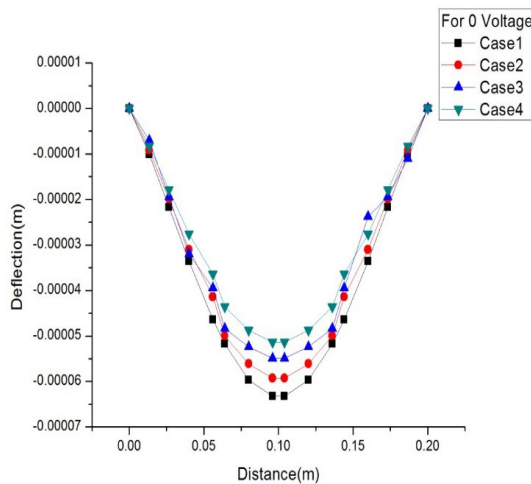

Fig 10: Centerline deflection for P=100N/m², V=0 for different cases

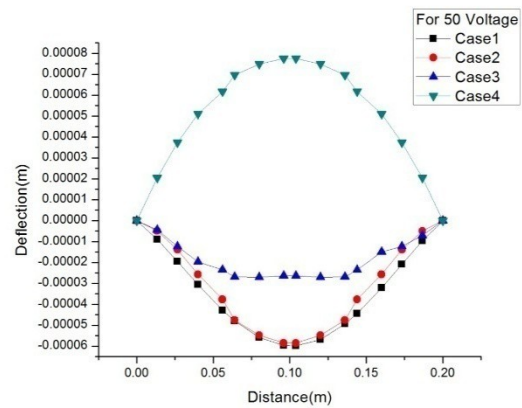

Fig 12: Centerline deflection for P=100N/m², V=50 for number of cases

V. CONCLUSION

A definite aspect of construction of the plate with piezoelectric of distributing sensors is accessible. A common process was improved for the constant shape organizing and controlling of the smart structure depending on the aspect of plate. With the existing method the input voltage and feedback gain will make the figure of the smart structure to attain the preferred shape. The performance of a piezoelectric laminated simply supported plate is studied. As a summary, the performance of the beam subjected to electric and mechanical loading are listed below:



1. The plate's deflection will decrease as relevant voltage increases.
2. It is concluded that the deflections because of mechanical loading can be effectively controlled by applying appropriate voltages to the piezo layers and can be said that piezoelectric layers are useful in controlling deflections of plate under electro mechanical loadings.
3. By studying the different cases of piezolayer, we conclude that piezolayer having at the heart of plate and distributed throughout plate have better shape control instead of extra two cases.

Reference;

- [1] (1970) Allik H. and Hughes Finite Element Method for Piezoelectric Vibration, "*International Journal for Numerical Methods in Engineering*" (151–157)
- [2] (2013) "Nonlinear Constitutive Modeling of Piezoelectric Materials" by Abdolali Zareian Jahromi University of Calgary.
- [3] "Optimal Size and Location of Piezoelectric Actuator/Sensors: Practical Considerations" &

Journal of Guidance, Control, and Dynamics by Aldraihem, T. Singh and R.C. Wetherhold](2000) (23:509-515)

[4], "*Mechanics of Composite Materials*" by Autar. K. Kaw- CRC Press, 2nd Edition, 2006 US.

[5] "Modeling and Shape Control of Composite Beams with Embedded Piezoelectric Actuators, *Composite Structures* "by Chandrasekhar, D. K. (1996) (35: 237–244)

[6] "Induced Strain Actuation of Isotropic and Anisotropic Plate *AIAA Journal*" (6:944-951) by Crawley and Lazarus (1991).